



TPU BELTS

THERMOPLASTIC POLYURETHANE



INTRALOGISTICS





INTRALOGISTIC SOLUTIONS

Making the logistical flow of material goods run smoothly is what matters in intralogistics, so your belt needs to be 100% reliable. The Gates intralogistics belt program combines the durability of top-quality products with optimal lead times and a reliable partnership, making it the number one choice for polyurethane synchronous belts. Our belts are designed to meet the specific needs of demanding, high-performance applications in automated warehouse systems. The wide product range covers an extensive variety of applications: conveyance, shuttles, automated storage and retrieval systems, and stacker cranes.



INTRALOGISTIC CONVEYING SYSTEMS

You can rely on Gates' polyurethane synchronous belts found in moving and conveying systems such as assembly lines within warehousing, storage & retrieval systems, shuttle systems, and conveyor transfer systems. Gates' belts guarantee 100% reliability under the most diverse circumstances to meet the needs of the materials handling

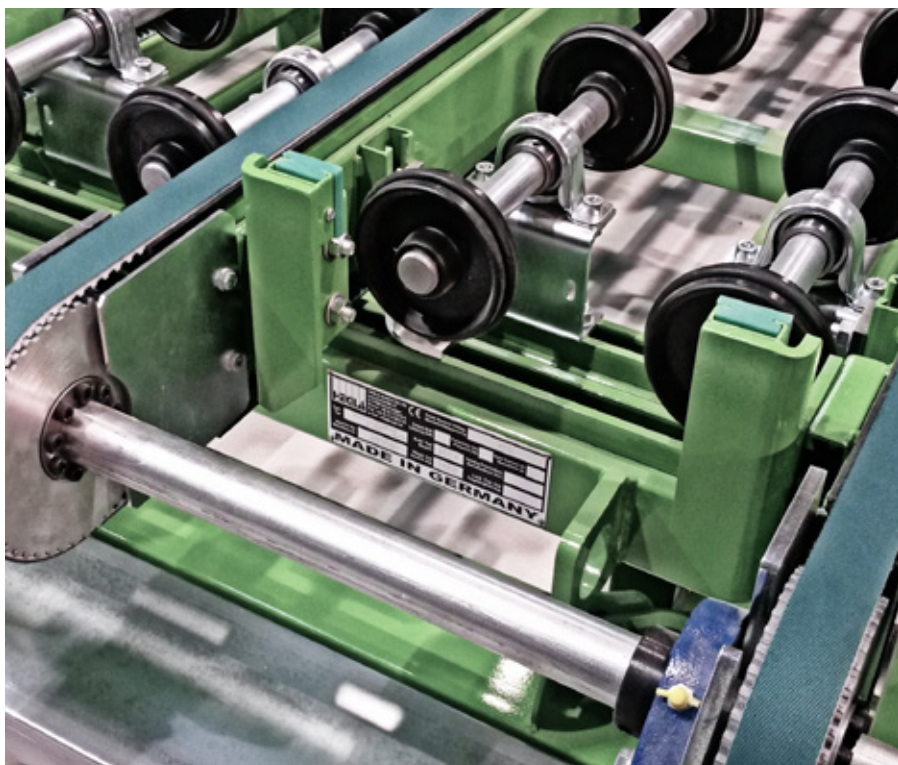
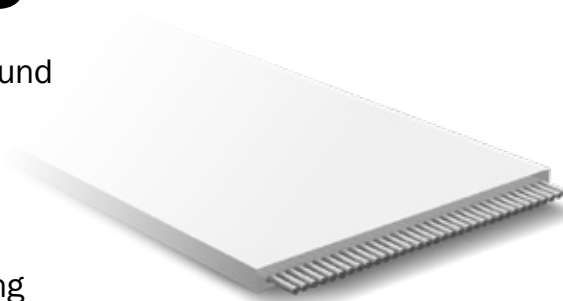

TIMING BELTS

T5ATB	Antistatic belt for transfer systems
AT5	For transfer conveyors
T10	For general conveyors, standard or low temperature PU grade
AT10	
AT20	For heavy load conveying

F160 LIVE ROLLER DRIVE BELT

- High friction, knurled diamond pattern on top ensures high grip and less slip on the rollers
- Low friction antistatic fabric on the bottom prevents static buildup
- Aramid cord design for lower stretch and longer life compared to competitor belts
- Designed to be spliced with OEM equipment
- Available in roll lengths up to 660 ft (200 meters)



ASR: AUTOMATED STORAGE AND RETRIEVAL SYSTEMS

Gates high tensile strength open-ended linear belts are designed for high-load and dynamic linear movements, making them the perfect fit for horizontal and vertical drives in mini-load warehouse systems. For take-off devices, Gates offers endless welded belt with or without backings.



FOR TAKE OFF DEVICES

T10	<ul style="list-style-type: none">• With high friction backings• Low temperature PU grades for cold storage available• Endless welded or endless flexbelt for small pulley diameters
AT5	
AT10	

FOR VERTICAL AND HORIZONTAL MOVEMENT

ATL10	<ul style="list-style-type: none">• The optimal belt selection for your specific machine design• With Nylon fabric on tooth side for less noise and low vibration• Low temperature PU grades for cold storage available• Various steel cord constructions for optimal tensile strength and high stiffness
AT20	
ATL20	
HTD8M	
HTDL8M	
HTD14M	
HTDL14M	
HPL14	



STACKER CRANES, PALLET STORAGE AND RETRIEVAL MACHINES

Tension within lifting applications puts much more strain on belts. Gates high-load timing and flat belts provide extreme tensile strength and stiffness thanks to the extra strong steel reinforcement of the belt. Resistant to forces up to 370 kN, our belts even exceed the industry standards to help you design state-of-the-art machines ready for the future.



HPL-14M

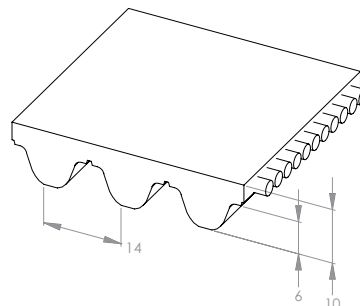

- High-performance synchronous belt
- PolyChain® 14M tooth shape - runs in HTD pulley
- Higher load carrying capacity due to extra high strength steel cord

SHUTTLE SYSTEMS

Gates power transmission belts drive the shuttles. Endless and open-ended PU belts work in telescope take-off systems in shuttles and Gates high load open end belts lift the boxes quietly and precisely to the conveyor systems.

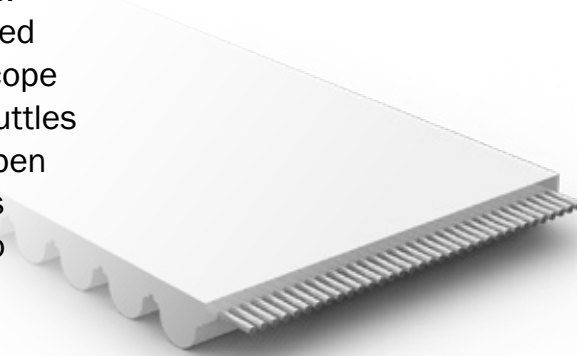

HTD8M

- High modulus tensile members giving length stability
- Accurate positioning
- High resistance versus tooth jumping
- Low noise, low vibration drives
- Gates HTD belts are available in various designs to fulfill diverse requirements in intralogistic applications



GT4

- Substantially increased power ratings: up to 30% more than previous constructions
- Compact, lightweight and cost-effective drives
- High capacity belt with reduced noise levels



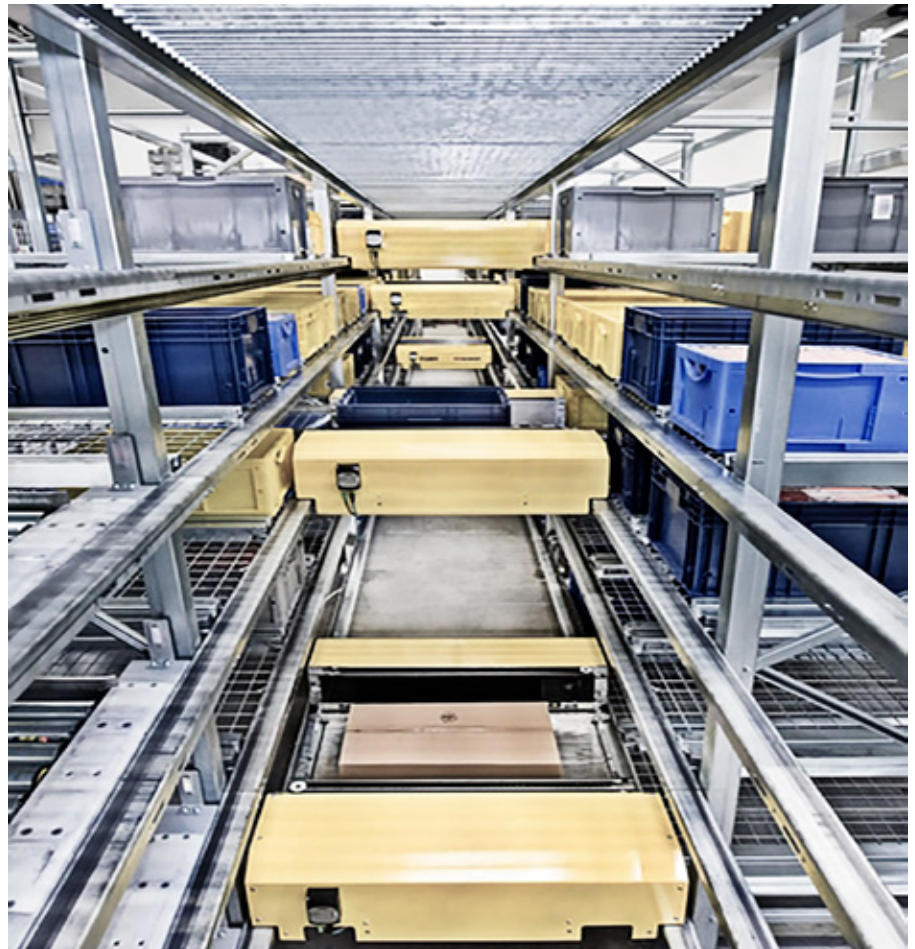

AT10

- For precision movement and high torque applications such as shuttle systems



E-BELT

- Used to drive telescoping arm applications





TPU BELTS

THERMOPLASTIC POLYURETHANE

Every day, design engineers, maintenance people, equipment manufacturers and their customers around the world rely on Gates' in-depth knowledge of the intralogistics industry to keep them running smoothly, safely and reliably. We specialize in material science and custom engineering support which results in true intralogistic system solutions. Gates is the ideal partner for all your intralogistic system design needs.

BROAD PRODUCT RANGE

Our extensive product range covers a wide variety of applications moving and conveying a diverse universe of articles and packaging.

UNRIVALED APPLICATION SUPPORT

Our engineering team will provide solutions that perfectly fit your application requirements.

GLOBAL SERVICE

Gates solves challenges globally with production and distribution partners worldwide.

RAPID DELIVERY

Gates provides fast quotation response and rapid delivery.

GATES.COM

Our catalog includes the complete product line up and technical data and is available to download from our website. Additional variations and special

NORTH AMERICA

Gates TPU
9 Northwestern Drive
Salem, NH 03079
Tel. +1 (800) 394-4844

EMEA

Gates TPU GmbH
Werner von Siemens Strasse 2
64319 Pfungstadt, Germany
Tel. +49 (0) 6157-9727-0