

Packaging Industry Conveyor and Processing Belts

Habasit – Solutions in motion

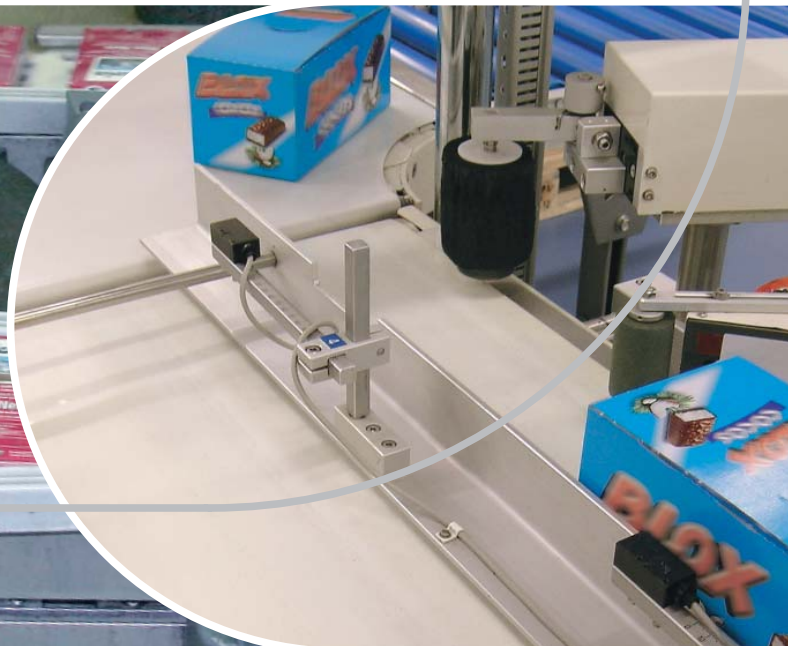

Contents

Solutions for the packaging industry	3
Process overview	4
Portfolio, features and benefits	
• HabaFLOW® fabric-based conveyor belts	10
• Habasit machine tapes	13
• HabaCHAIN® slat and conveyor chains	14
• Habicord round belts	14
• HabasitLINK® plastic modular belts	15
• HabaSYNC® timing belts	16
• Seamless belts	17
Application table	18
Services	22
The Habasit solution	23
Habasit worldwide	24

This **disclaimer** is made by and on behalf of Habasit and its affiliated companies, directors, employees, agents and contractors (hereinafter collectively "HABASIT") with respect to the products referred to herein (the "Products"). SAFETY WARNINGS SHOULD BE READ CAREFULLY AND ANY RECOMMENDED SAFETY PRECAUTIONS FOLLOWED STRICTLY! Please refer to the Safety Warnings herein, in the Habasit catalogue as well as installation and operating manuals.

All indications / information as to the application, use and performance of the Products are recommendations provided with due diligence and care, but no representations or warranties of any kind are made as to their completeness, accuracy or suitability for a particular purpose. The data provided herein are based on laboratory application with small-scale test equipment, running at standard conditions, and do not necessarily match product performance in industrial use. New knowledge and experience may lead to re-assessments and modifications within a short period of time and without prior notice.

EXCEPT AS EXPLICITLY WARRANTED BY HABASIT, WHICH WARRANTIES ARE EXCLUSIVE AND IN LIEU OF ALL OTHER WARRANTIES, EXPRESS OR IMPLIED, THE PRODUCTS ARE PROVIDED "AS IS". HABASIT DISCLAIMS ALL OTHER WARRANTIES, EITHER EXPRESS OR IMPLIED, INCLUDING, BUT NOT LIMITED TO, IMPLIED WARRANTIES OF MERCHANTABILITY, FITNESS FOR A PARTICULAR PURPOSE, NON-INFRINGEMENT, OR ARISING FROM A COURSE OF DEALING, USAGE, OR TRADE PRACTICE, ALL OF WHICH ARE HEREBY EXCLUDED TO THE EXTENT ALLOWED BY APPLICABLE LAW. BECAUSE CONDITIONS OF USE IN INDUSTRIAL APPLICATION ARE OUTSIDE OF HABASIT'S CONTROL, HABASIT DOES NOT ASSUME ANY LIABILITY CONCERNING THE SUITABILITY AND PROCESS ABILITY OF THE PRODUCTS, INCLUDING INDICATIONS ON PROCESS RESULTS AND OUTPUT.



Meeting the challenge

Due to a great number of stringent regulations and increasing market competition, the packaging industry faces major challenges. Companies must conform with statutory and market requirements, especially when handling delicate materials such as foods, chemicals, pharmaceuticals or dangerous goods. This often leads to increased costs. At the same time, customers are also demanding a wider array of innovative products, higher quality standards, and more flexibility and speed.

To secure a competitive advantage, improve productivity, and avoid unexpected production stoppages, companies in the packaging industry need to embrace innovative technologies. By choosing the right conveyor and processing belts they can achieve major process improvements, higher productivity, and lower maintenance costs.

Innovation is a key word at Habasit

Our extensive range of solutions enables our customers to choose the best product for their applications.

Competence and experience

Habasit's application engineers, technicians and joining specialists are on call to provide professional consulting, superb customer service and excellent support. Founded in 1946, Habasit has proved its understanding of customer needs for more than 60 years. Our comprehensive global network means that Habasit can consistently respond to any request with world-class, premium-quality belting solutions tailored to your specific needs.



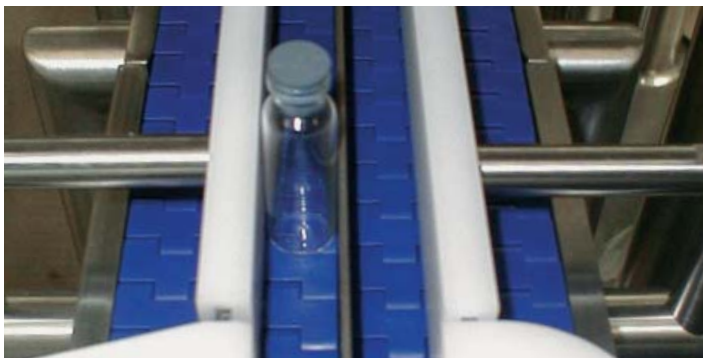

Vertical form fill machine (VFFS)

- Feeding conveyor (inclined)
- Vertical FFS belts
- Conveying section



Blister

- Filling station
- Outfeed unit

Check weigher/labelling

- Label application
- Check weigher
- Label pressing

Cartoning

- Folded carton infeed
- Carton opening and feeding station
- Flap locking



Wrapping

- Infeed
- Wrapping
- Flap sealing
- Outfeed

Shrink wrapping and packing line

- Collation
- Tray feed
- Tray flap sealing
- Wrapping
- Shrink wrapping
- Case packing
- Palletizing
- Conveying/warehouse transport



Bundling

- Infeed
- Wrapping
- Flap sealing
- Outfeed

Case packing

- Infeed
- Collation
- Insertion
- Case sealing
- Conveying/warehouse transport





Blister machine

Belts in application:

- Food belts
- High-duty belts
- Machine tapes

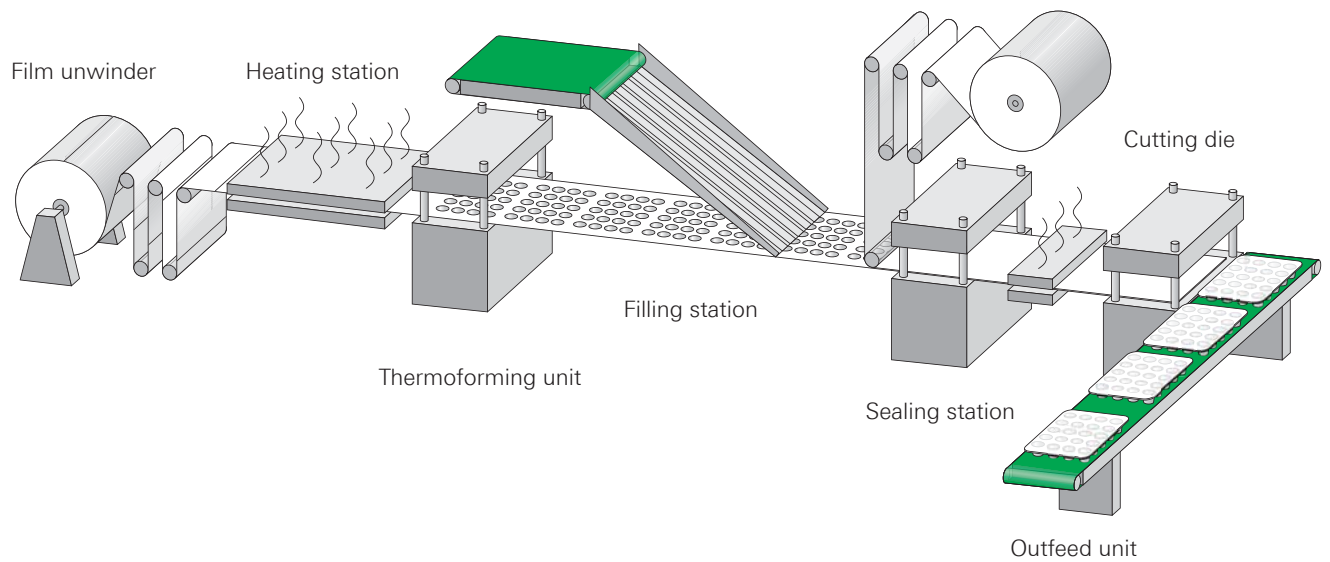

These drawings show schematic examples of selected applications and processes, and are neither complete nor comprehensive. The belt recommendations (use/application/layout) can only be considered as a general suggestion. Due to the complexity of the various processes and technical requirements, and external influences such as the nature or properties of the transported goods, process speeds, stages of treatment/handling, environmental or process temperatures, humidity, chemicals, additives, ingredients, and recipes, etc. there are many possible solutions.

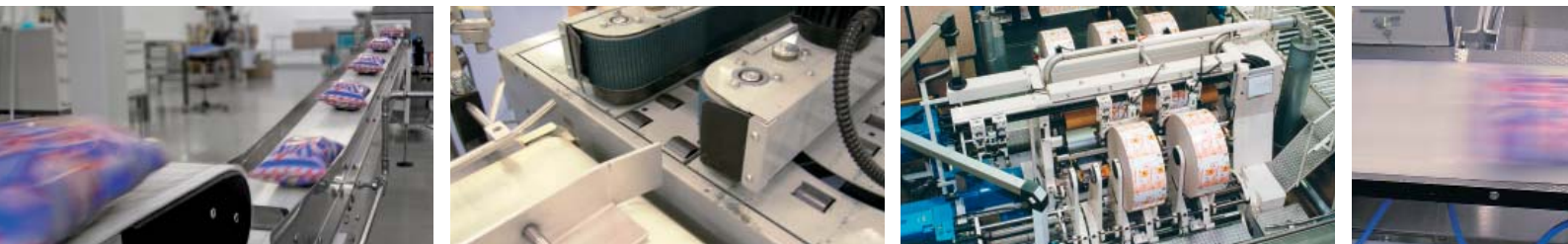

Vertical form fill seal machine (VFFS)

Belts in application:

- GRABBER® seamless belts
- Food belts
- Conveyor belts
- N-line belts

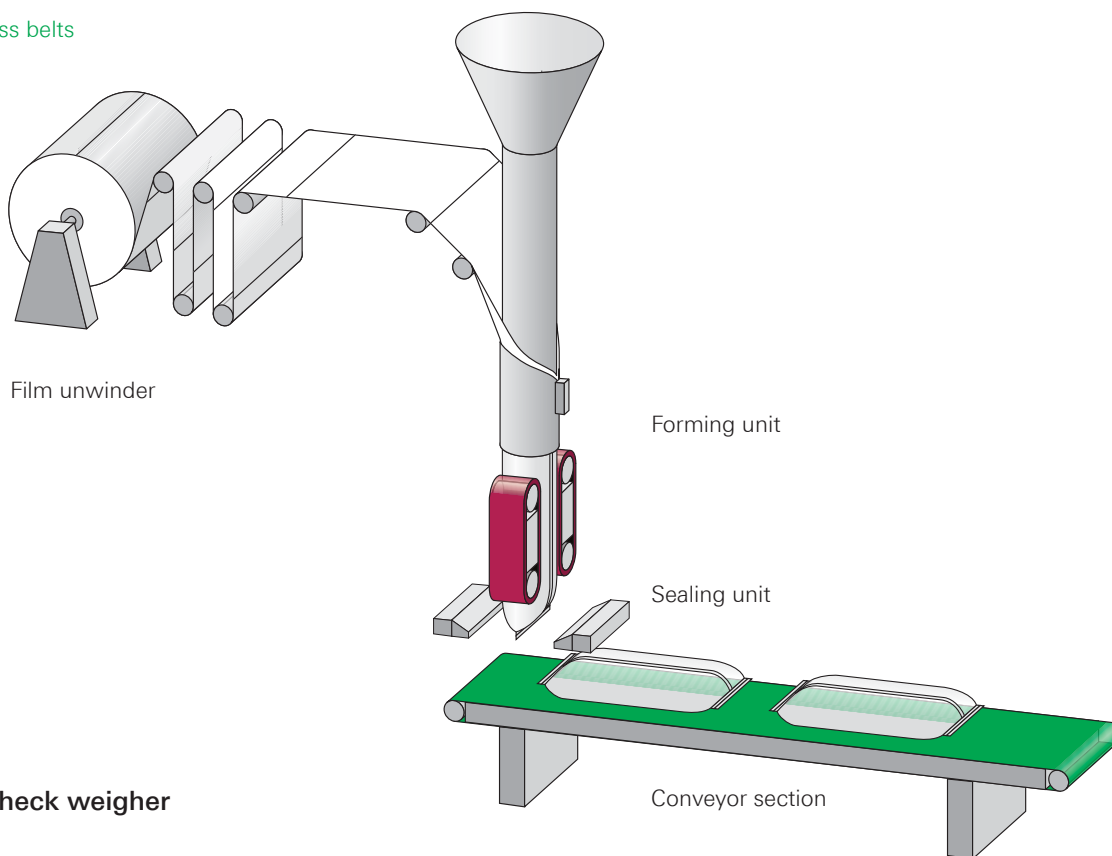

Labelling unit – check weigher

Belts in application:

- GRABBER® seamless belts
- Seamless belts
- Food belts
- Conveyor belts
- N-line belts

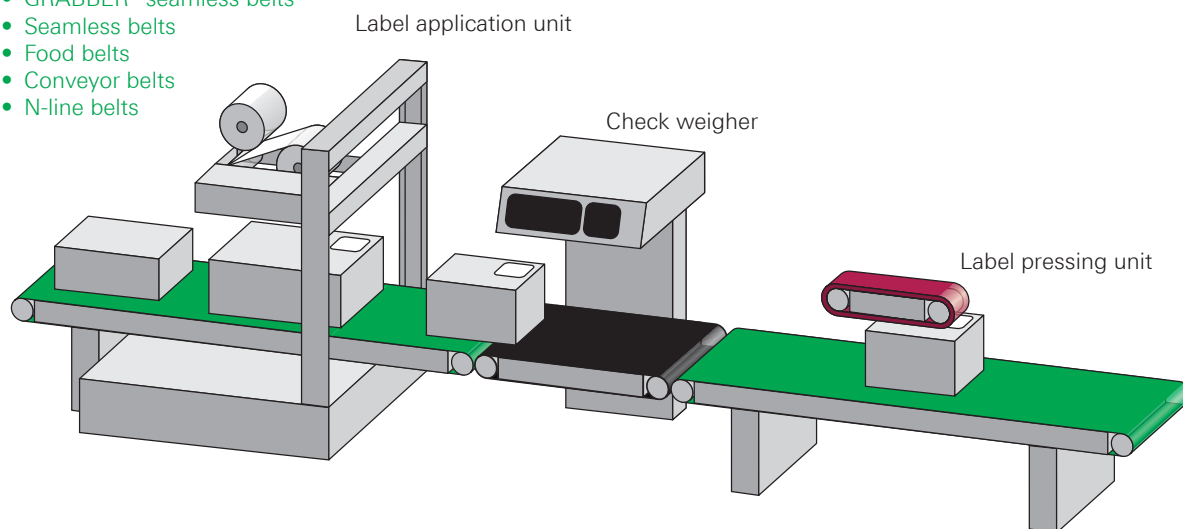



Cartoning machine

Belts in application:

- HabasitLINK® modular belts
- HabaSYNC® timing belts
- N-line belts
- Food belts
- Habasit Cleandrive™ belts

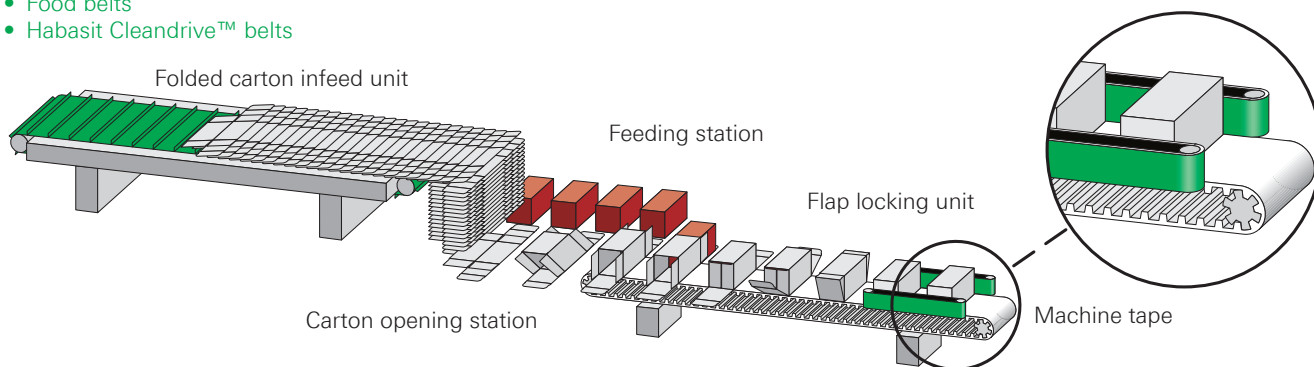

Wrapping machine

Belts in application:

- GRABBER® seamless belts
- Food belts
- Conveyor belts
- N-line belts
- Machine tapes
- Habasit Cleandrive™ belts

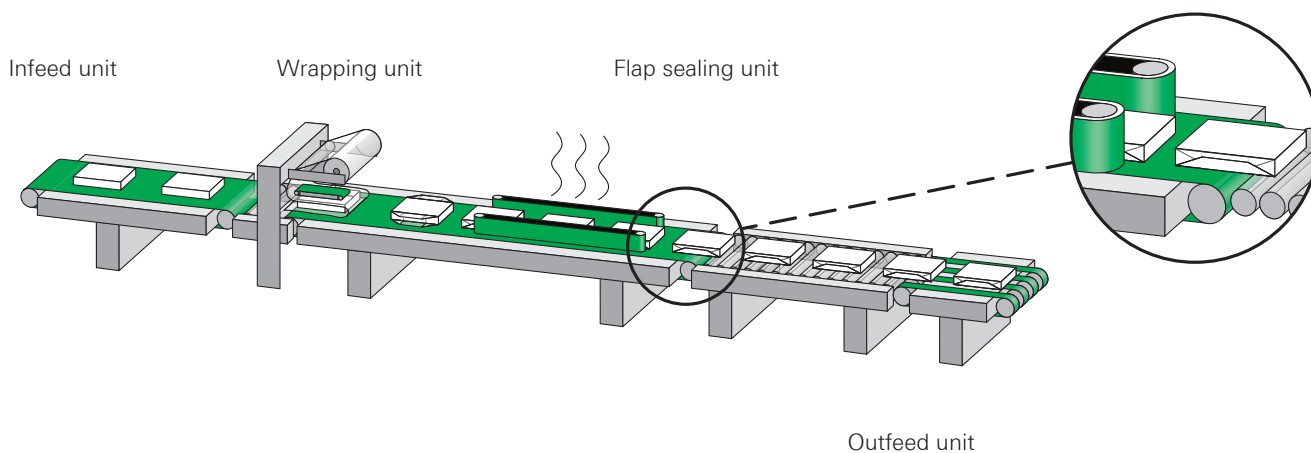

These drawings show schematic examples of selected applications and processes, and are neither complete nor comprehensive. The belt recommendations (use/application/layout) can only be considered as a general suggestion. Due to the complexity of the various processes and technical requirements, and external influences such as the nature or properties of the transported goods, process speeds, stages of treatment/handling, environmental or process temperatures, humidity, chemicals, additives, ingredients, and recipes, etc. there are many possible solutions.

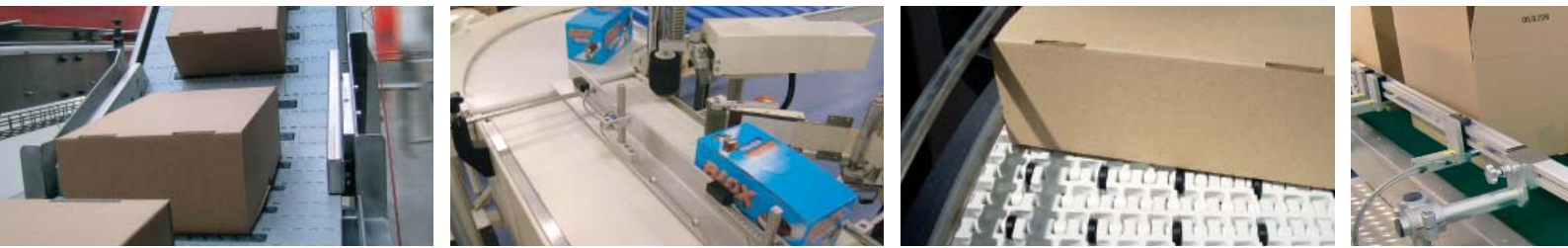

Bundling machine

Belts in application:

- GRABBER® seamless belts
- Food belts
- Conveyor belts
- N-line belts
- Machine tapes

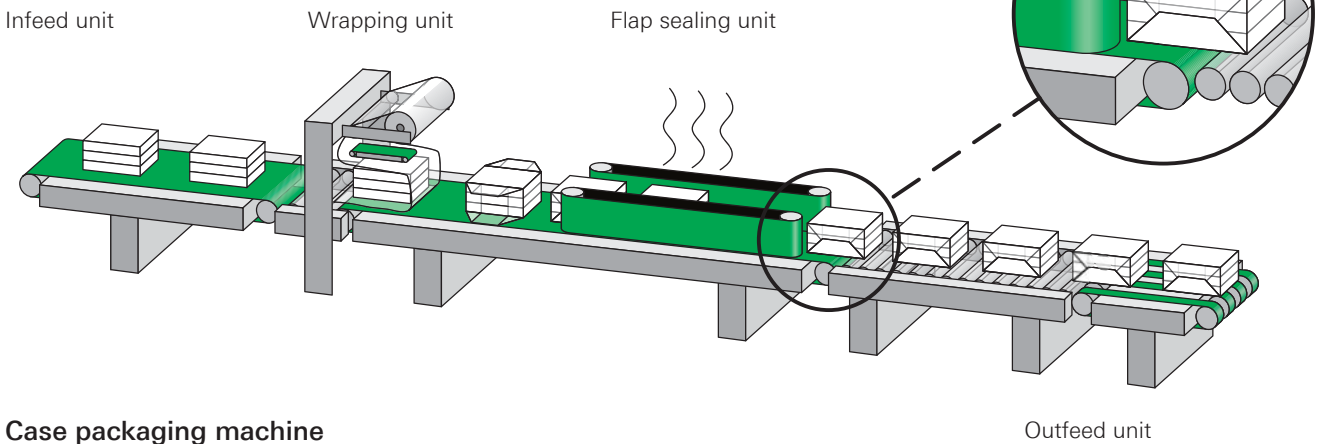

Case packaging machine

Belts in application:

- HabasitLINK® modular belts
- HabaSYNC® timing belts
- Food belts
- Conveyor belts
- N-line belts
- High-duty belts

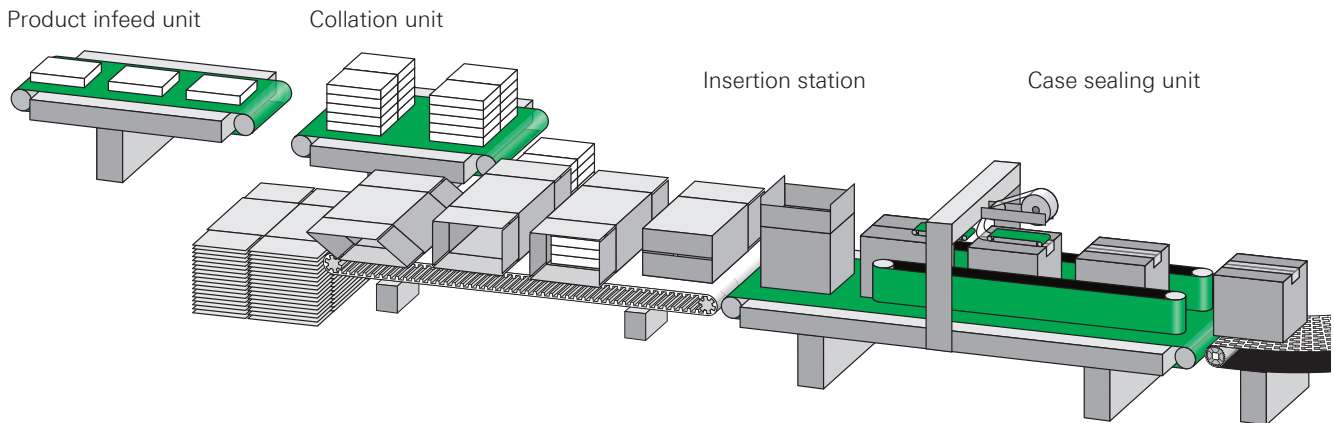

These drawings show schematic examples of selected applications and processes, and are neither complete nor comprehensive. The belt recommendations (use/application/layout) can only be considered as a general suggestion. Due to the complexity of the various processes and technical requirements, and external influences such as the nature or properties of the transported goods, process speeds, stages of treatment/handling, environmental or process temperatures, humidity, chemicals, additives, ingredients, and recipes, etc. there are many possible solutions.

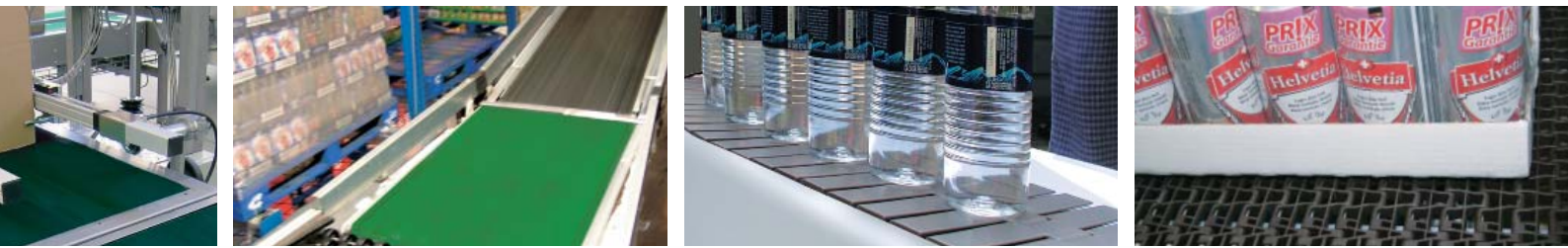

Belts in application:

- HabasitLINK® modular belts
- Food belts
- Conveyor belts
- N-line belts
- High-duty belts
- Machine tapes

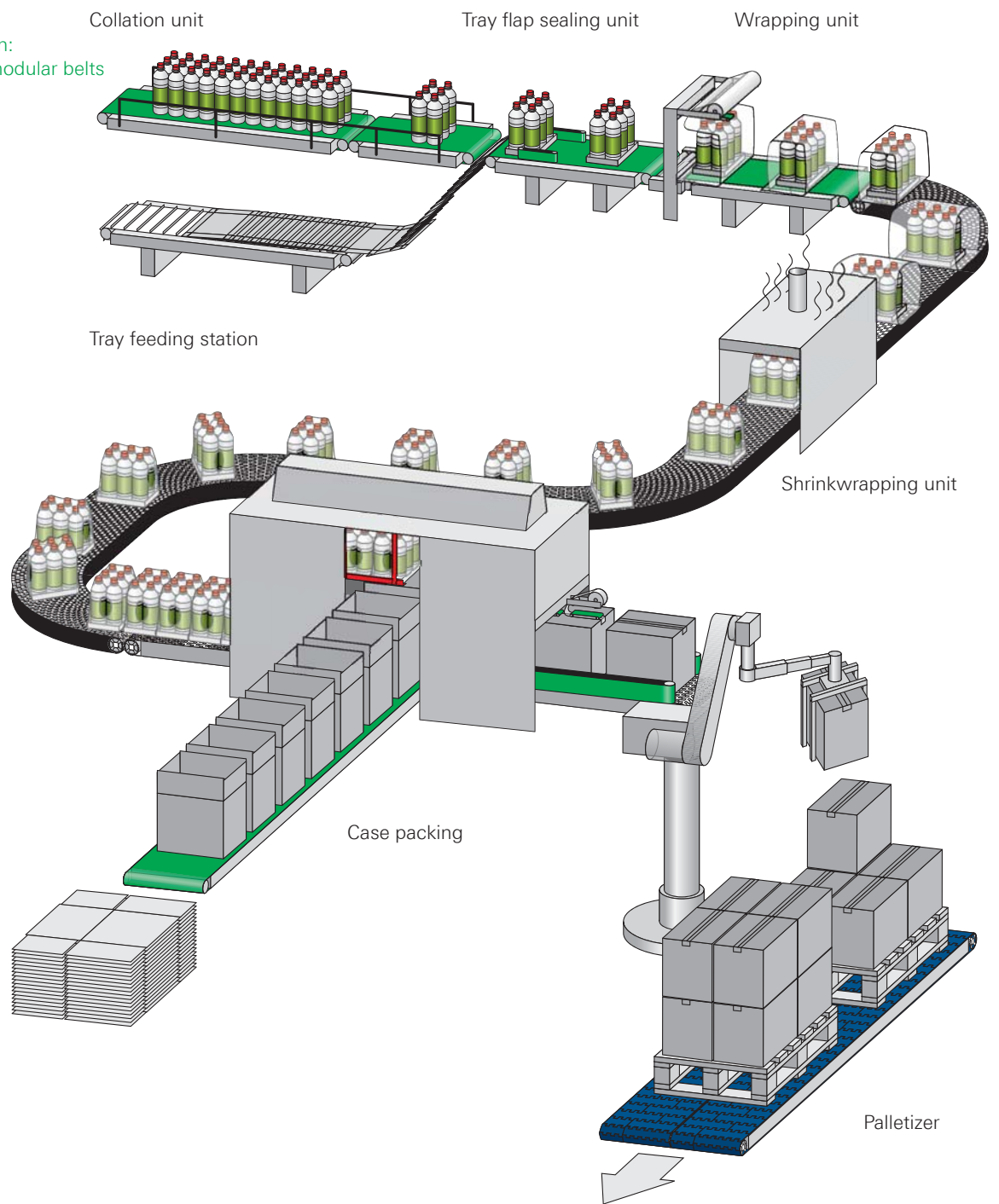

The right belt for every application

Habasit's conveyor belt selection includes hundreds of different belts to satisfy application requirements that range from straight-inclined or declined operations, to accumulation and diverters, to swan neck (Z) conveyors, and numerous others. We offer a wide variety of tension members and cover materials, as well as structural conveying- and running-side patterns to optimize your system's performance.

Belt materials

The materials and designs are selected to cope with a broad range of application requirements, including resistance to wear or chemical agents, and to high or low temperatures. Furthermore, our belts maintain excellent stress-strain behavior through the use of carefully selected tension members.

Belt design

Habasit conveyor and processing belts are generally made of different layers, with tensile strength provided by synthetic fabric plies. These fabrics are connected by layers of thermoplastic materials. The material, thickness and texture of the conveying side depend on the function of the belt.

Cover coatings are mainly made of thermoplastic materials like TPU, TPO, PVC, etc., and elastomer-like rubbers, PUR, etc. – or feature a fabric cover. The running side is usually a fabric, often impregnated with a thermoplastic material, or with special wear-resistant PUR that provides a low and constant coefficient of friction. There are also pulley-side fabrics that feature special low-noise running capabilities.

Attachments and profiles

Guides, cleats and side walls are the most common modifications applied to conveyor and processing belts. While V-shaped profiles are mostly attached to the running side as guides, various cleat designs can be welded or bonded to the conveying side to ensure proper transport either horizontally or on an incline. Side walls positioned close to the edges of the belt stop loose goods falling off.

Surface structure

A well-designed belt surface supports both the secure transport of the goods conveyed as well as the process where the belt is employed. Careful selection is essential in order to find the right belt for each conveying or processing application. The belt surface plays a key role in meeting each specific process step or function.

Selection of surface structures



Blank, smooth

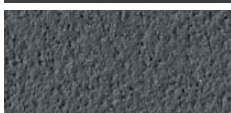

Super matt finish (sand finish)

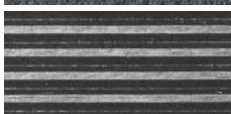

Longitudinal groove structure



Jink wave (sine wave) grip structure



Grip (rough top) structure



Quadrille (quadrangular pattern) structure



Waffle structure



Nonwoven (fleece, buffed or ground finish) structure

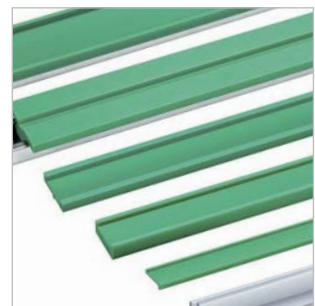
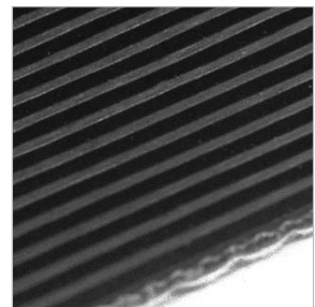
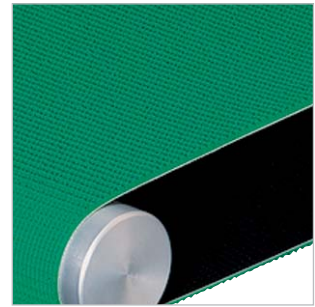

Food conveyor and processing belts



Key features	Your benefits
<ul style="list-style-type: none"> • Wide range of surface types, structures, belt strengths and special features available 	<ul style="list-style-type: none"> → Selection of the most suitable belt for specific applications like feeding, accumulation, releasing, metal detection, check weighing, etc.
<ul style="list-style-type: none"> • Full compliance with food regulations such as FDA and USDA (US), EU Directive (Europe), etc. 	<ul style="list-style-type: none"> → Comply with food safety regulations, especially for processing and packaging of sensitive goods
<ul style="list-style-type: none"> • Excellent adoptability of special fabrications such as profiles, side walls, marking, tracking guide, edge sealing, etc. 	<ul style="list-style-type: none"> → Meet the technical requirements for applications like pick and place → Proper belt tracking → No stringing prevents contamination
<ul style="list-style-type: none"> • Extruded positive driven and flat belts – Habasit Cleandrive™ 	<ul style="list-style-type: none"> → The ultimate hygienic belt design, combining proven features of different belting categories

Silicone coated belts



Key features	Your benefits
<ul style="list-style-type: none"> • Easy release property of silicone-coated conveying side of the belt 	<ul style="list-style-type: none"> → Easy release of delicate products and contaminated sticky residues from the belt, such as hot melt adhesive for flap sealing and labelling of cartons
<ul style="list-style-type: none"> • Excellent high- and low-temperature resistance 	<ul style="list-style-type: none"> → Suitable for high-temperature film packing applications such as overwrapping, shrink packaging, hot melt adhesive applications, etc.
<ul style="list-style-type: none"> • Full compliance with food regulations for the selected belts such as FDA and USDA (US), EU Directive (Europe), etc. 	<ul style="list-style-type: none"> → Maintains the food safety required, especially for food packaging applications when necessary

PVC coated belts



Key features	Your benefits
<ul style="list-style-type: none"> • Wide range of surface types, structures and belt strengths available 	<ul style="list-style-type: none"> → Selection of the most suitable belt for specific applications like feeding, accumulation, general conveying, etc.
<ul style="list-style-type: none"> • Stable modulus of elasticity after running-in 	<ul style="list-style-type: none"> → No re-tensioning required and reduced downtime possible, leading to easy maintenance
<ul style="list-style-type: none"> • Permanently antistatic belts available 	<ul style="list-style-type: none"> → No re-tensioning required while maintaining high stability of the belt, enabling downtime to be reduced
<ul style="list-style-type: none"> • Simple and fast joining method (Flexproof) 	<ul style="list-style-type: none"> → No interference with the conveyed products, less dust and dirt attraction, more reliable processing

N-line belts



Key features	Your benefits
<ul style="list-style-type: none"> • Wide range of surface types, structures and belt strengths available 	<ul style="list-style-type: none"> → Selection of the most suitable belt for specific applications like feeding, accumulation, general conveying, etc.
<ul style="list-style-type: none"> • Stable modulus of elasticity after running-in 	<ul style="list-style-type: none"> → No re-tensioning required, with reduced downtime possible, leading to easy maintenance
<ul style="list-style-type: none"> • Permanently antistatic belts available 	<ul style="list-style-type: none"> → No re-tensioning required, while maintaining high stability of the belt, enabling downtime to be reduced
<ul style="list-style-type: none"> • Simple and fast joining method (Flexproof) 	<ul style="list-style-type: none"> → No interference with the conveyed mass, less dust and dirt attraction, more reliable processing

High-duty belts



Key features	Your benefits
<ul style="list-style-type: none"> • Wide range of surface types, structures and belt strengths available with enhanced mechanical, thermal and chemical resistance 	<ul style="list-style-type: none"> → Selection of the most suitable belt for specific applications, especially packaging applications where improved mechanical, thermal and chemical resistance is required
<ul style="list-style-type: none"> • High-grip rubber surface such as NBR and EPDM featured in selected belts 	<ul style="list-style-type: none"> → Constant coefficient of friction → Gentle handling of sensitive goods → Reliable product flow in incline and decline conveyors
<ul style="list-style-type: none"> • Longitudinal flexibility and dimensional stability for TPU coated belts 	<ul style="list-style-type: none"> → Suitable for mini-, Z-, checkweighing and transfer conveyors featuring small pulley diameters and nose bars, which are common in many packaging machines
<ul style="list-style-type: none"> • Abrasion- and cutting-resistant properties for PUR coated and PA belts 	<ul style="list-style-type: none"> → Suitable for lateral loading, diverting and accumulation applications in packaging machines where the belt needs very robust strength

Comprehensive, reliable range

Machine tapes are central to manufacturing operations. They convey, speed up, slow down, position and, when required, fold the paper material processed. Habasit's comprehensive range of Hamid, polyamide and polyurethane machine tapes are manufactured with abrasion-resistant NBR covers or other application-oriented surface materials. They provide the industry with effective and comprehensive belting solutions that are extremely reliable, have constant grip, and offer a long service life.

Design

The tapes feature a composite construction with a Hamid (Habasit thermoplastic compound or thermoplastic foil), or polyamide, or polyurethane traction layer. A wide range of surface materials, such as NBR rubber, TPU, EPDM, PUR, and PA are available in different structures for both sides.

Materials

Hamid: The design of the Hamid machine tapes allows them to be joined quickly by fusing the ends together without the use of adhesives. This results in a superior product with uniform flexibility over the whole length. In addition, it provides significant cost savings in terms of maintenance and reduced downtimes. Elastic Hamid machine tapes are also available. **Polyamide:** The traction layer of these machine tapes is highly resilient and can cope with intermittent overloads, which prevents residual elongation. This makes re-tensioning unnecessary, and avoids costly and time-consuming machine downtimes

Hamid machine tapes



Key features	Your benefits
<ul style="list-style-type: none"> Uniform longitudinal flexibility and dimensional stability 	<ul style="list-style-type: none"> → Suitable for compact design applications with small pulley diameters → Low costs and long life
<ul style="list-style-type: none"> Excellent abrasion resistance and constant coefficient of friction 	<ul style="list-style-type: none"> → Good for gentle handling of the conveyed products required in many packaging machines
<ul style="list-style-type: none"> Stable modulus of elasticity after running-in and low sensitivity to humidity 	<ul style="list-style-type: none"> → No re-tensioning required, while maintaining high stability of the belt, enabling downtime to be reduced
<ul style="list-style-type: none"> Simple, fast and adhesive-free joining method (Flexproof) 	<ul style="list-style-type: none"> → Easy handling of belt replacement without disassembling the packaging machine, enabling machine downtime to be dramatically reduced

Polyamide (PA) machine tapes



Key features	Your benefits
<ul style="list-style-type: none"> High strength and resilience, with longitudinal flexibility and dimensional stability 	<ul style="list-style-type: none"> → Suitable for compact design applications with small pulley diameters → Can cope with intermittent overloading in the packaging application
<ul style="list-style-type: none"> Excellent abrasion resistance and constant coefficient of friction 	<ul style="list-style-type: none"> → Good for gentle handling of the conveyed products required by many packaging machines
<ul style="list-style-type: none"> Stable modulus of elasticity after running-in 	<ul style="list-style-type: none"> → No re-tensioning required, while maintaining high stability of the belt and enabling downtime to be reduced
<ul style="list-style-type: none"> Permanently antistatic belting available 	<ul style="list-style-type: none"> → No interference with the conveyed products, less dust and dirt attraction, reliable processing

HabaCHAIN® slat and conveyor chains

Designed, produced, and serviced by the worldwide leader in belting, the HabaCHAIN® range offers top-class innovation and quality combined with excellent reliability and cost-efficiency. HabaCHAIN® products are available in both straight-running and radius/side-flexing versions, and run on most systems and sprockets on the market today. They are fully compatible with industry standards, making them ideal for retrofitting. The chain elements are high-precision injection-molded single plastic parts linked to each other with pins. These run engaged over sprockets and idlers on profile guides. Selected chain elements are available in stainless steel.

Accessories

The accessories range includes: inserts to increase friction between product and chain, “bakery bends” for smooth lateral product transfer, stainless steel attachments, extended pins or half-round pushers, and much more.



Key features	Your benefits
<ul style="list-style-type: none"> • High tensile strength 	→ Reduces downtime while maximizing conveyor layout
<ul style="list-style-type: none"> • Low-friction material available 	→ Excellent for high-speed applications on various packaging machines
<ul style="list-style-type: none"> • Bevel edges and high-friction inserts 	→ Product stability over multiple strand conveying, enabling unique product conveying solutions
<ul style="list-style-type: none"> • Wide range of specialty materials available 	→ Coverage for all packaging application requirements

Habicord round belts

Habasit round belts are highly flexible, directionally adjustable, and multi-directional for angular gears. They can be used for conveying as well as for driving applications. As a result of their elasticity, round belts can be installed without a tensioning device. This allows compact machine designs. In addition, the elasticity acts as a security element by reducing shocks in case of brief overloads. Round belts are highly resilient and their physical and chemical characteristics are exceptional in many areas: their resistance to hydrolysis is significantly superior to that of most existing polyurethane elastomers. As a result, Habasit round belts are resistant to water, oils, grease and benzene.

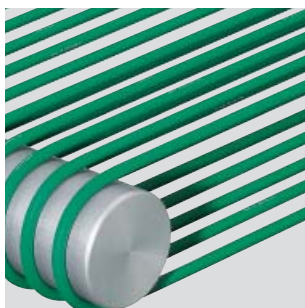

Key features	Your benefits
<ul style="list-style-type: none"> • Excellent abrasion resistance and constant coefficient of friction 	→ Good for gentle handling of the conveyed products required by many packaging machines
<ul style="list-style-type: none"> • Smooth surface of the belt 	→ Easy release of wrapping materials such as plastic film and foil, avoiding wrapping material sticking to the belt
<ul style="list-style-type: none"> • Excellent oil resistance 	→ Good for continuous use of the belt even when oily foodstuffs such as meat and poultry are conveyed for packaging
<ul style="list-style-type: none"> • Simple, fast and adhesive-free joining method (quick melt) 	→ Easy handling of belt replacement without disassembling the packaging machine, enabling machine downtime to be dramatically reduced

Advantageous in numerous applications

The modular belt is an aggregation of individual plastic modules made by high-precision injection molding and connected by lateral rods. Its robust design is optimized for efficient conveying and easy cleaning procedures.

Plastic modular belts eliminate the need for high-tension systems by positively engaging the sprocket with the running belt and maintaining proper belt tracking. They are widely used in many industries, where their specific product features provide numerous benefits to our customers

Materials

Habasit modular belts are available with a variety of state-of-the-art features, including special materials for: low friction, self-lubrication, chemical resistance, food-approved materials, as well as with antistatic, flame retardant, magnetic, detectable, electrically conductive, submersible, anti-microbial, special-impact, cut-resistant, high-temperature, and super high-temperature properties.

Sprockets and rods

Injection-molded sprockets have a specific open design that allows easy access for cleaning across the width of the conveyor shafts. Wear-resistant materials secure a long lifetime in all applications. The full-width rods ensure belt connection and lateral stiffness. HabasitLINK® modular belts come with two rod solutions, depending on the belt type: Smart Fit and Snap Fit.

Accessories

Habasit offers a wide range of modular belt accessories including cleats, flights, scoops, side guards, finger transfer plates, and hold-down tabs for elevators with back bending (Z-conveyors), as well as HabiPLAST® guide rails.

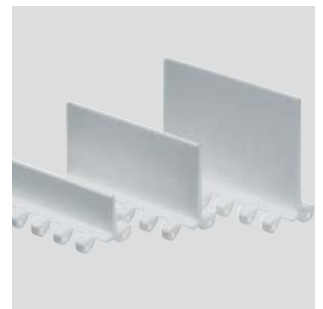
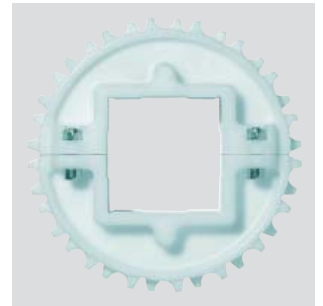

Surface structures (selection only)



Flat Top



GripTop



Radius Grip-Top



Flush Grid



LBP low back pressure



Roller Top



Key features

- Assembled in a brick-layered pattern connected with solid plastic rods
- Positive drive and tracking system by engaging the belt with sprockets
- Various types of materials available
- Quick installation and easy maintenance

Your benefits

- High flexibility in terms of width and length, with lateral strength
- Accessories such as flights, scoops, and side walls can be placed as required
- No need for high tensioning systems, maintains proper belt tracking alignment
- Choice of materials to meet a wide range of packaging application requirements, operating temperatures and chemical resistance
- Easy, belt installation and maintenance with minimum downtime

World-leading synchronized conveying

The demand for synchronized conveying has grown significantly over the past two decades. As machines moved faster and precision output became a greater engineering challenge, it was obvious that no conveying solutions existed to reliably and cost-effectively meet customers' needs.

Borrowing knowledge and experience from over 60 years as a market-leading conveyor belt manufacturer, Habasit built a new state-of-the-art production plant to manufacture thermoplastic urethane synchronous timing belts for our global customer base. Utilizing our broad global affiliate company network and their fabrication skills, we are now able to design tailored solutions for customers worldwide.

Covers

Habasit offers a broad selection of covers for our HabaSYNC® timing belts. Covers provide the friction needed to handle products so that they are correctly indexed and securely and effectively managed. Our covers are designed to cope with a wide variety of requirements and can thus guarantee reliable conveyance in every type of transport function and manufacturing application.

Special fabrications

Modifications to the conveying and tooth sides of HabaSYNC® timing belts can enhance the performance of your conveying and linear-positioning applications. Additional machining steps are common, such as holes for vacuum draw, pockets for product reading and deposit recognition, slots for handling, and lateral grooves for venturing. Habasit's high investment in automated processes ensures that our belts deliver the consistent precision you require.

Profiles and tracking guides

Profiles, added with thermal-bonding processes or mechanical attachment, allow unique positioning and adjustment. Thermoplastic profiles are made in several ways: extrusion, injection molding or machining. The choice of profile sourcing depends on the shapes, dimensions and quantities required.

Integrated guide belts and weld-on tracking guides are available to ensure proper tracking. The tracking guide is placed on the tooth side of the timing belt. This provides true belt tracking in applications where long narrow belts are used.

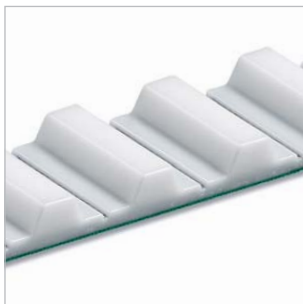
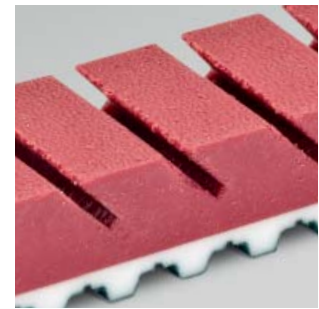
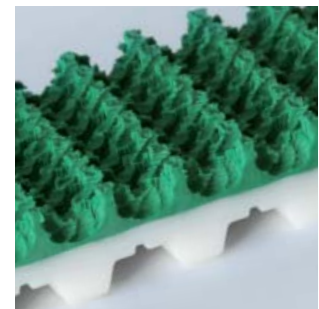
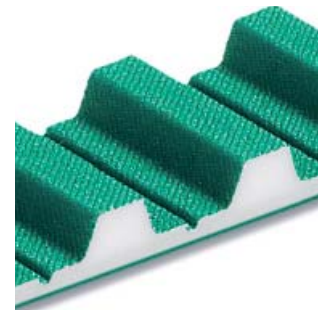

Key features	Your benefits
<ul style="list-style-type: none"> All pitches designed for precise synchronous conveying and linear movement 	<ul style="list-style-type: none"> → Suitable for applications where exact positioning is required in the packaging machine
<ul style="list-style-type: none"> Selection of special fabrications such as covers, profiles, tracking guides, machining modifications, etc. 	<ul style="list-style-type: none"> → Enables highly custom-engineered timing belts according to specific requirements
<ul style="list-style-type: none"> Option of polyamide and/or antistatic fabric on both sides, tooth side only and conveying side only 	<ul style="list-style-type: none"> → Offers low friction and low noise when conveying products and engaging with pulleys
<ul style="list-style-type: none"> Ease of on-site joining by specially designed joining press machine and hinge joint system 	<ul style="list-style-type: none"> → Enables belt installation and replacement without disassembling the packaging machines, leading to reduced downtimes and costs

Customized belts for special needs

Seamless belts are custom-engineered for specific application needs. They are made of endless woven substrate components like polyester, nylon, cotton, Kevlar or Nomex. The substrate is impregnated with an elastomer, such as neoprene, nitrile, EPDM, polyurethane, Hypalon, silicone, or other special compounds. The materials used depend on the application.

Belt design

The belt substrate (fabric) is woven endless on looms as a tubular hose. The threads are wound in a spiral in the belt drive running direction. The belt circumference is determined by the diameter of the spirals, while the required width is obtained by slitting the hose.

Materials

Rubber coated seamless belts: GRABBER® series

- Cover material: natural rubber, neoprene, nitrile, EPDM, polyurethane, Hypalon and special compounds
- Substrate material: polyester, nylon, cotton, Kevlar, Nomex and special materials

Rubber impregnated traditional style seamless belts: Panther and Apache series

- Cover material: neoprene, nitrile, EPDM, polyurethane, Hypalon, silicone, etc.
- Substrate material: polyester, nylon, cotton, Kevlar, Nomex, etc.

Seamless belts – GRABBER® series



Key features	Your benefits
<ul style="list-style-type: none"> • Truly seamless (no seam on the belt) and fully vulcanized cover lamination process 	<ul style="list-style-type: none"> → Prevents belt joint and cover lamination failure, enabling a longer belt life than a joined belt
<ul style="list-style-type: none"> • Numerous types of substrates including flat and timing belts and durable cover materials with precise thickness 	<ul style="list-style-type: none"> → High performance of the belt and reliable and consistent processing over the entire service life
<ul style="list-style-type: none"> • Excellent adoptability of various machining modifications 	<ul style="list-style-type: none"> → Enables highly custom-engineered seamless belts to be designed according to requirements
<ul style="list-style-type: none"> • Smooth and vibration-free belt performance 	<ul style="list-style-type: none"> → Ensures high performance of the belt and extremely long flex life

Seamless belts – Panther and Apache series



Key features	Your benefits
<ul style="list-style-type: none"> • Truly seamless (no seam on the belt) 	<ul style="list-style-type: none"> → Prevents belt joint failure, enabling a longer belt life than a joined belt
<ul style="list-style-type: none"> • Numerous types of substrates made of endless woven components with precise thicknesses 	<ul style="list-style-type: none"> → Ensures high performance of the belt and reliable and consistent processing over the entire service life
<ul style="list-style-type: none"> • Excellent adoptability of various machining modifications 	<ul style="list-style-type: none"> → Enables highly custom-engineered seamless belts to be designed according to requirements
<ul style="list-style-type: none"> • Low power requirements 	<ul style="list-style-type: none"> → Energy savings for light power transmission and conveying purposes in packaging applications

Remark: This application/belt matrix is neither complete nor comprehensive and serves only as a guide to potential solutions. For detailed material and belt selection, please contact your local Habasit partner: www.habasit.com

	Seamless belts		HabasitLINK® plastic modular belts																			
	GRABBER® series	Panther series	M0870 Micropitch	M0885 Micropitch Flush Grid	M1220 Flat Top	M1220 Grip Top	M1230 Flush Grid	M2420 Flat Top	M2470 Flat Top	M2510 Flat Top	M2520 Flat Top	M2520 GripTop	M2533 Flush Grid	M2533 GripTop	M2585 Flush Grid	M2620 Flat Top Heavy Duty	M2620 GripTop	M2670 Flat Top Heavy Duty	M3840 Radius Flush Grid	M3843 Tight Radius	M3843 Tight Radius GripTop	
Vertical form fill machine (VFFS)																						
Forming unit	•																					
Conveying section			•	•	•	•	•	•	•	•	•	•	•	•		•	•	•	•	•	•	•
Blister																						
Filling station			•	•	•		•			•			•							•	•	
Outfeed unit			•	•	•	•	•	•	•		•	•										
Check weigher/labelling																						
Label application unit							•					•		•				•				
Check weigher		•			•		•	•	•				•									
Label pressing	•					•						•		•				•				
Cartoning																						
Folded carton infeed					•		•				•		•									
Carton opening and feeding station																						
Flap locking																						
Wrapping																						
Infeed			•	•	•	•	•	•	•		•	•		•		•	•	•	•	•	•	•
Wrapping	•																					
Flap sealing																						
Outfeed					•		•				•		•									
Shrinkwrapping and packaging																						
Collation			•	•	•		•	•	•		•	•	•	•		•		•				
Shrink wrapping															•							
Conveying/warehouse transport			•	•	•	•		•	•		•	•				•	•	•				
Bundling																						
Infeed					•	•	•	•	•					•		•	•	•		•	•	•
Case packing																						
Infeed			•	•	•	•	•	•	•		•	•				•	•	•				
Collation					•			•	•		•					•		•				
Insertion																						
Case sealing	•																					
Conveying/warehouse transport			•	•	•	•		•	•		•	•				•	•	•		•	•	•

Comprehensive services are central to Habasit’s belting solution approach.

As committed partners to our customers, we are dedicated to sharing our knowledge and to providing full support.



Comprehensive consulting and technical support

Habasit offers the best consulting and technical support on the belting market. Everything revolves around our customers: each affiliate has its own belting experts. The Habasit team is proud to provide the highest levels of support, together with top-quality products that have been leaders on the global market for decades.

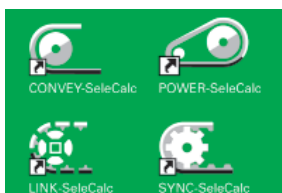

Assistance with belt selection and calculation

We will select and calculate the most suitable belt for your specific application. You can also do this yourself with our state-of-the-art Habasit selection and calculation program “SeleCalc”. To order this program free of charge, simply call your nearest Habasit partner or contact: info@habasit.com.



Fabrication, assembly and local installation services for quick reaction times

We make belts endless or assemble modular belts or chains, either at our own locations or on-site directly on your machine or system. Habasit operates over 30 affiliated companies worldwide, each with its own inventory, fabrication, assembly and service facilities. Together with our representative offices and numerous qualified distributors, we can react quickly, competently and reliably to satisfy all your demands.



Tools for on-site fabrication

Because we understand your processes, we can support you with cost-effective, high-quality tools that keep your equipment up and running. In case of emergency our tools will help to minimize breakdown time and support the joining process.



Habasit offers skivers to prepare the belt ends of polyamide power transmission belts and spindle tapes prior to joining. Finger cutting devices to prepare aramide and polyester power transmission belts and TPU spindle tapes are also available. A selection of hot pressing devices to fit your applications and guarantee optimum quality of joining complement the range.

Customer training programs

Habasit offers training programs and provides support tools to ensure optimal use of our products and to prolong their lifetimes. Training on fabrication, installation, assembly, maintenance and belt repair takes place at Habasit sites or at your location.



Belt monitoring, inspections, analyses and process optimization proposals

We organize and handle belt maintenance, inspections, analyses and surveys for your locations. On request we will also work with you to develop optimization proposals, for example, to achieve added value from your machinery or process output.

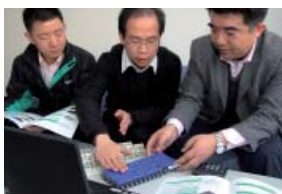

Design assistance for customized solutions

Habasit believes in partnership. Our engineering team will work closely with your engineers on joint design developments, preferably from a very early stage. We particularly recommend this for projects involving new technologies or large-scale modifications and adaptations.



Customers first

At Habasit we understand that our success depends on your success. This is why we offer solutions, not just products; partnership, not just sales.

Since our foundation in 1946, Habasit has brought this understanding of customer needs to life every day and for every application. That's why we're the No. 1 in belting today. Worldwide.

Learn more at www.habasit.com

Committed to innovation

Because our customers' belting challenges and needs never cease, we consistently dedicate a substantial percentage of our employees and resources to the research and development of new products and solutions.

Certified for quality

We deliver the highest quality standards not only in our products and solutions, but also in our employees' daily work processes. Habasit AG is certified according to ISO 9001:2008.



Worldwide leading product range

Habasit offers the largest selection of belting, conveying, processing and complementary products in the industry. Our response to any request is always a specific, tailor-made solution.

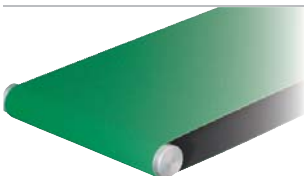

Fabric-based conveyor and processing belts
HabaFLOW®



Plastic modular belts
HabasitLINK®

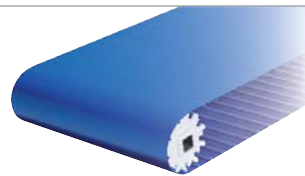

Positive drive conveyor and processing belts
Habasit Cleandrive™



Power transmission belts
HabaDRIVE®



Timing belts
HabaSYNC®



Chains (slat and conveyor chains)
HabaCHAIN®

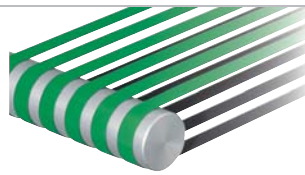

Machine tapes

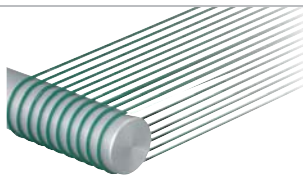

Round belts



Seamless belts

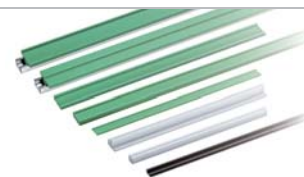

Profiles, Guides, Wear strips
HabiPLAST®



Fabrication tools (joining tools)



Gearmotors
Electric motors
Motion control

Austria

Habasisit GmbH
Wien
Phone: +43 1 690 66
www.habasisit.at

Belgium

Habasisit Belgium N.V.
Zaventem
Phone: +32 27 250 430
www.habasisit.be

Canada

Habasisit Canada Ltd.
Oakville
Phone: +1 905 827 41 31
www.habasisit.ca

China

Habasisit East Asia Ltd.
Hong Kong
Phone: +85 221 450 150
www.habasisit.com.hk

Habasisit (Shanghai) Co. Ltd.
Shanghai
Phone: +8621 5488 1228
Phone: +8621 5488 1218
www.habasisit.com.hk

France

Habasisit France S.A.S.
Mulhouse
Phone: +33 389 338 903
www.habasisit.fr

Germany

Habasisit GmbH
Eppertshausen
Phone: +49 6071 969 0
www.habasisit.de

India

Habasisit-lakoka Pvt. Ltd.
Coimbatore
Phone: +91 422 262 78 79
www.habasisitiakoka.com

Italy

Habasisit Italiana SpA
Customer Care:
Phone: 199 199 333
For int. calls: +39 0438 911 444
www.habasisit.it

Japan

Habasisit Nippon Co. Ltd.
Yokohama
Phone: +81 45 476 0371
www.habasisit.co.jp

Netherlands

Habasisit Netherlands BV
Nijkerk
Phone: +31 332 472 030
www.habasisit.nl

New Zealand

Habasisit Australasia Ltd.
Hornby
Phone: +64 3348 5600
www.habasisit.co.nz

Norway

Habasisit Norge A/S, Oslo
Phone: +47 815 58 458
www.habasisit.no

Poland

Habasisit Polska Sp. zo.o.
Dąbrowa Górnicza
Phone: +48 32639 02 40
www.habasisit.pl

Russia

OOO Habasisit Ltd.
St. Petersburg
Phone: +7 812 600 40 80
www.habasisit.ru

Singapore

Habasisit Far East Pte. Ltd.
Singapore
Phone: +65 686 255 66
www.habasisit.com.sg

Spain

Habasisit Hispanica S.A.
Barberà del Vallès
Phone: +34 937 191 912
www.habasisit.es

Sweden

Habasisit AB
Hindas
Phone: +46 30 122 600
www.habasisit.se

Switzerland

Habasisit GmbH
Reinach
Phone: +41 61 577 51 00
www.habasisit.ch

Taiwan

Habasisit Rossi (Taiwan) Ltd.
Taipei Hsien
Phone: +886 2 2267 0538
www.habasisit.com.tw

Turkey

Habasisit Kayis San. Ve Tic. Ltd. Sti.
Yenibosna-Bahcelievler-Istanbul
Phone: +90 212 654 94 04
www.habasisit.com.tr

Ukraine

Habasisit Ukraine LLC.
Vinnitsa
Phone: +38 0432 58 47 35
www.habasisit.ua

United Kingdom and Ireland

Habasisit (UK) Ltd.
Silsden
Phone: +44 844 835 9555
www.habasisit.co.uk

USA

Habasisit America
Conveyor belts, power
transmission belts, gearmotors
Suwanee, Georgia
Phone: +1 800 458 6431
www.habasisitamerica.com

Habasisit America
Seamless belts, timing belts
Middletown, Connecticut
Phone: +1 860 632 2211
www.habasisitamerica.com

Rossi is one of Europe's largest manufacturers of gear reducers, gearmotors, inverters, standard and brakemotors, and is a member of the Habasisit Group.

Rossi S.p.A.
Via Emilia Ovest 915/A
41123 Modena – Italy
Phone: +39 059 33 02 88
www.rossi-group.com
info@rossi-group.com

Headquarters

Habasisit AG
Römerstrasse 1
CH-4153 Reinach, Switzerland
Phone +41 61 715 15 15
Fax +41 61 715 15 55
E-mail info@habasisit.com
www.habasisit.com

Registered trademarks
Copyright Habasisit AG
Subject to alterations
Printed in Switzerland
Publication data:
2078RO.PAC-en0414HQ